

SNITT 1-1 M 1:25

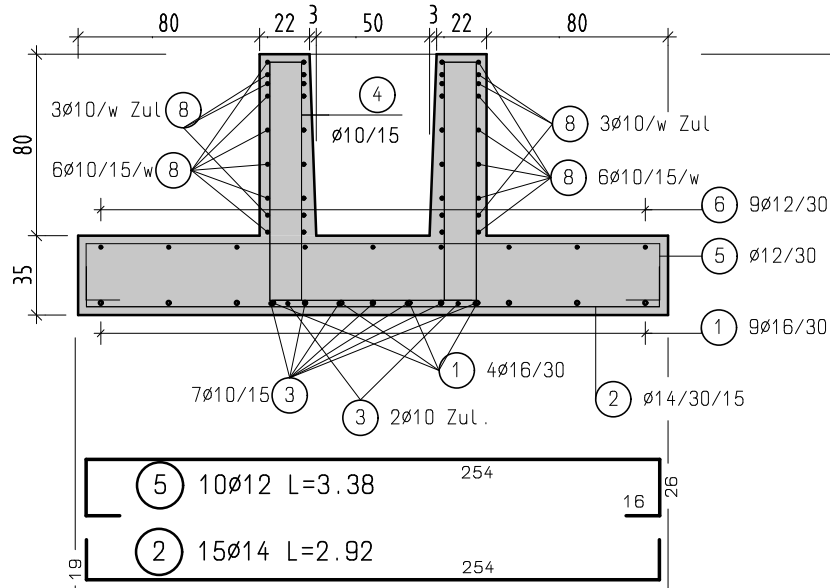

GRUNDRISS M 1:25

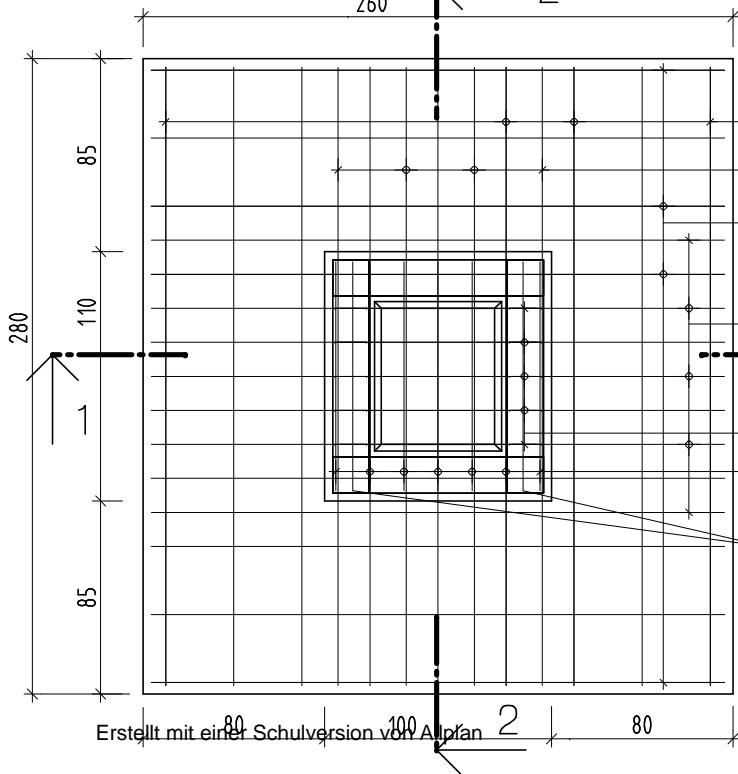

SNITT 2-2 M 1:25

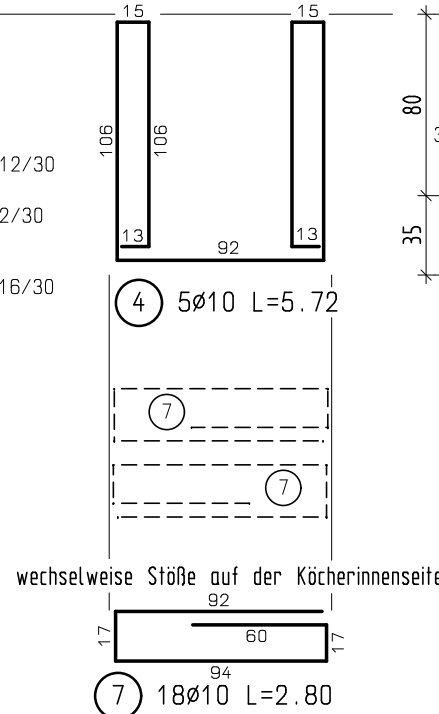
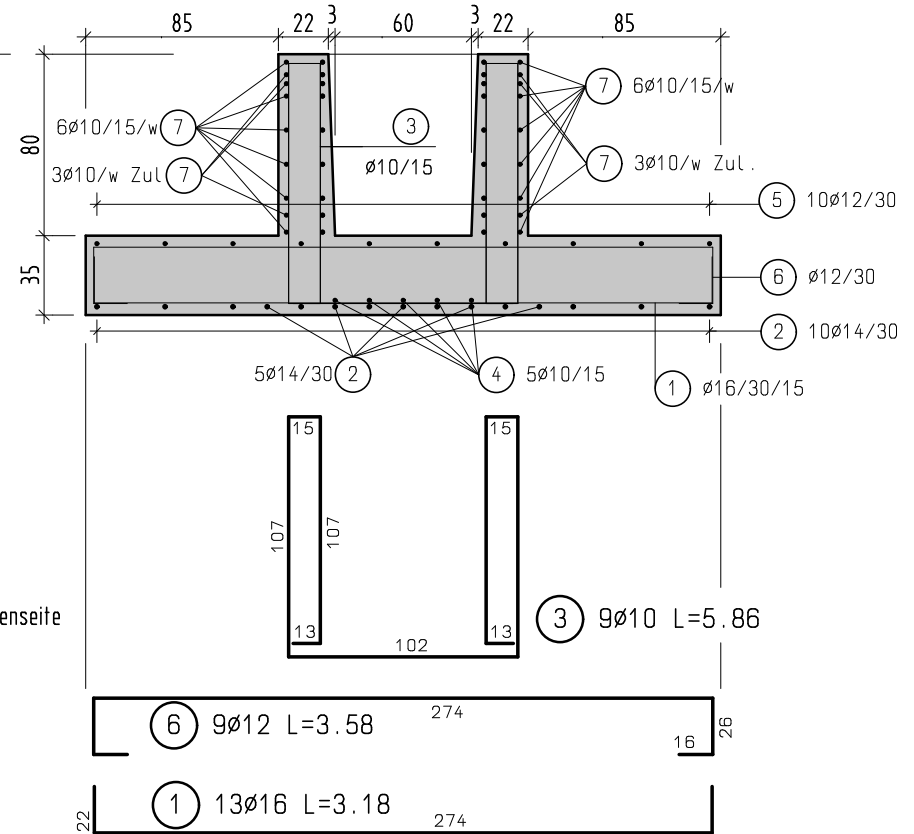

BAUSTOFFE:
 BETON: C20/25 GK 16
 STAHL: BST 550
 Betondeckung: 3,0cm
 Kächer innenseite: 2,0cm

Pos.	Stck	ø [mm]	Einzell. [m]	Gesamtl. [m]	Masse [kg]
1	13	16	3.18	41.34	65.32
2	15	14	2.92	43.80	53.00
3	9	10	5.86	52.74	32.54
4	5	10	5.72	28.60	17.65
5	10	12	3.38	33.80	30.01
6	9	12	3.58	32.22	28.61
7	18	10	2.80	50.40	31.10
8	18	10	3.00	54.00	33.32
Gesamtmasse [kg]:					291.55